

Storage and Installation of HOLLOW METAL FRAMES

By Rachel S. Smith, in conjunction with the members of the HMMA Promotions and Education Committee.

PROPER STORAGE AND INSTALLATION OF hollow metal doors and frames is critical to having an opening (frame, door and hardware) that will function properly and pass the fire door inspection. This article is based on the Hollow Metal Manufacturers Association (HMMA) Standard HMMA 840-07, entitled "Guide Specification for Installation and Storage of Hollow Metal Doors and Frames."



(HMMA) is one of six divisions of NAAMM, the National Association of Architectural Metal Manufacturers. The other divisions are Metal Bar Grating (MBG), Detention Equipment Manufacturers Association (DEMA), Architectural Metal Products (AMP), Expanded Metal Manufacturers Association (EMMA), and the Expanded Metal Lath Association (EMLA). Literature for HMMA and a member directory can be found on line at www.hollowmetal.org. More information about the other divisions can be found at www.naamm.org.

The author of this article, Rachel S. Smith, is a member of the Promotions and Education Committee of HMMA. AIA Continuing Education (CEU) credits are available for learning this material by going to www.ronblank.com and looking in the Section 8 classes. HMMA also has an online course on Fire Rated Doors and Frames. These classes are also available for presentation at local chapter meetings of both DHI and CSI.

GENERAL CONTRACTOR: JOB SITE RESPONSIBILITIES:

Installation of materials starts with delivery of these materials to the job site and storing them until the installation is ready to commence.

1. Inspection of materials

The installing contractor's job site responsibilities start with inspecting the material being delivered to make sure it's not damaged, defective or wrong. If material is damaged, the options are to refuse delivery (reject the material) or accept the material and sign for it as being damaged. Claims are not honored by freight carriers unless they are noted on the freight bill in as much detail as possible, including the number of doors and frames with a description of the damage.

If there is damaged, defective or wrong material, it is critical that the contractor notify the supplier (distributor or manufacturer) immediately. Failure to report these situations could result in warranty cancellation, loss of fire-label integrity, rejection of any field repair costs or loss of any opportunity of replacement. The manufacturer must be allowed sufficient time to initiate any corrective measure in the field so they can participate in solving the problem. Most HMMA members have their own field representatives who are qualified not only to do expert repair work but also to determine whether the fault lies with the manufacturer or with other parties.

2. Storage of Materials

It is then critical that the material be properly stored. The doors and frames need to be protected from weather and stored in accordance with HMMA 840. Figures 1 and 2 show the proper storage of the material. The main steps in proper storage are:

1. Store all materials in a dry area, under cover.
2. Do not use non-vented plastic or canvas.
3. Store doors and frames in an upright position.
4. Place no more than 5 doors or welded frames in a group.
5. Place all materials on planking

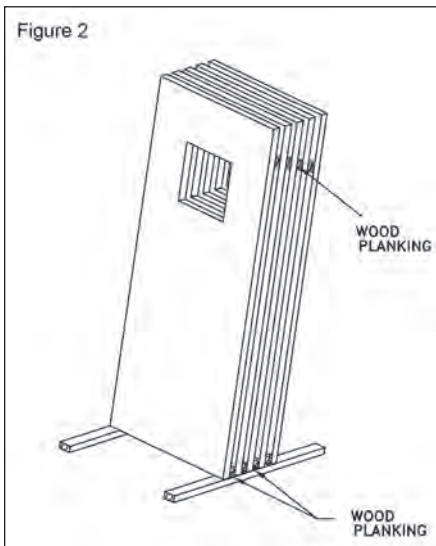
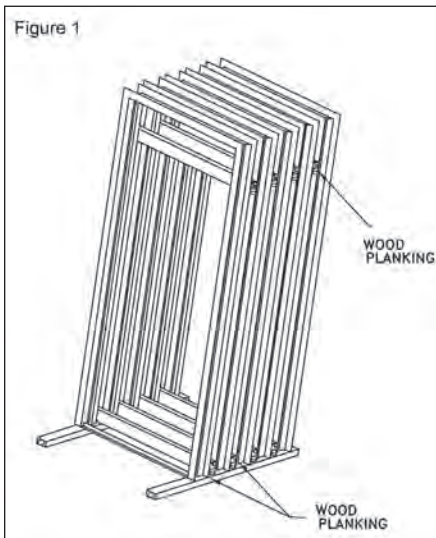

or blocking at least 4" off the ground, or 2" off paved area or floor slab.

6. Provide at least 1/4" between all units for circulation of air.
7. Store material in an area of low moisture to assure that it does not get wet. Material that rusts during storage will need to be inspected for rust and repaired or replaced as needed.

3. Pre-Installation Tasks

Before beginning installation of each unit, the installing contractor must check the mark numbers of the material and check size and swing. It is imperative that the correct frame is installed in the correct location. It is a very common error for the wrong frame to be installed in the opening, which creates hardware, coordination, handing and sizing errors that surface late in the construction process. This coordination starts with making sure the correct mark numbers are given to the manufacturer when ordering the materials.

Shipping bars, located at the base of welded frames, must be removed and not used as installation spreaders; these are there just to keep the frame square during the transportation to the job site. This is one of the most misunderstood parts of the installation process. If someone asks when the shipping bars should be removed during the installation, the answer is before installation is started. They are not part of the installation process.

4. Installation of Materials

Most field problems of hollow metal doors and frames relate to installation deficiencies. This article just hits the highlights of HMMA 840. Refer to the document for more complete information regarding this subject and for information on door installation.

Installation of Welded Hollow Metal Frames

The advantages of a correctly installed frame are:

- Longer life of the frame, door and hardware.
- Correct clearances, especially as required to pass building inspection of fire rated openings.
- Proper operation of the unit, including latching, and closing of the door.
- Less maintenance to keep the opening functioning correctly.

Throughout the entire process of installation, the frame must be checked to be sure it's plumb and square. If the frame is not set plumb and square with no twist, the door and hardware will not function properly or the door may not even fit into the frame at all. This is not the fault of the manufacturer; the frame was produced square, but it can be racked out of shape during the installation process.

Spreader Bars and Squaring the Welded Frame:

Remove the shipping bars and do not use them as installation spreaders. Wood spreaders are typically used for installation. One spreader is installed at the bottom of the frame, and a second spreader at either mid height or strike location (Figure 3). The frame is then squared and braced.

Install additional wood spreaders as needed for taller jamb opening heights or for face dimensions of less than 1 1/2". Additional spreaders are needed for sidelight frames where the sill intersects the door jamb.

Level the head of the frame by positioning the level to the

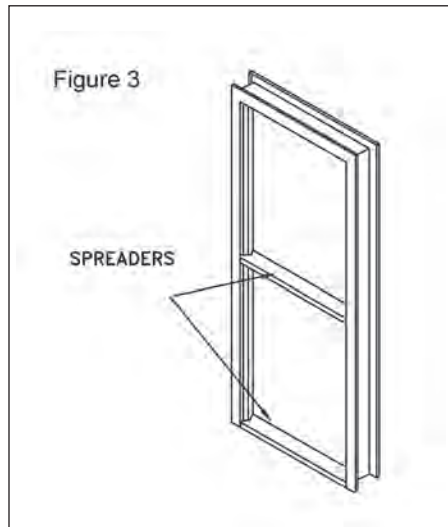

head door rabbet, then position a builder's square against the jamb and head at the door rabbet. Adjust the frame as required to assure it is square and level (Figures 4 and 5).

Using a carpenter level, check frame for plumbness and alignment (Figure 6). For plumbness, position the level against both the hinge and strike jambs in the rabbet. Alignment is checked by positioning the level against both the hinge and strike jambs on the stop. Adjust as need for plumbness and alignment until everything is correct.

Check the jambs for twist using a builder's square. Position the square against the door rabbet and project a line perpendicular to the plane of the door rabbet. Adjust as required.

Anchoring a Welded Frame:

There are three main wall types that welded frames are anchored into:

- New masonry
- Wood or steel stud walls
- Existing masonry

Each one will be treated separately, although there are some commonalities. First of all, the anchors need to be selected for the type of wall that the frame is being installed into. There are multi-purpose anchors available that can work with a multiple of these frame

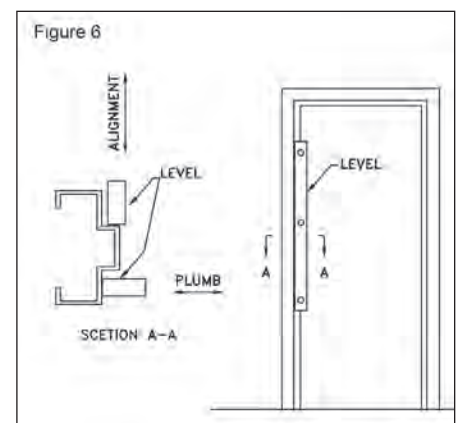
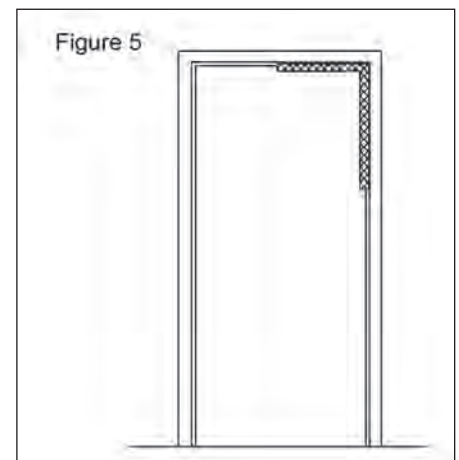
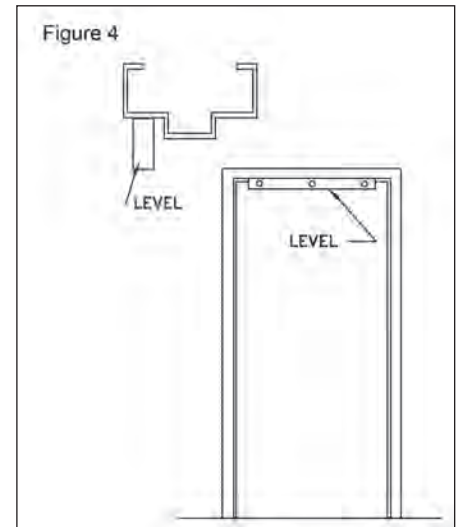

types, and they have to be adjusted appropriate for the wall condition.

Proper anchors are vitally important to the proper performance of the door opening. There are variations in design between manufacturers, but the performance remains the same.

The required anchor quantity per jamb differs with wall construction

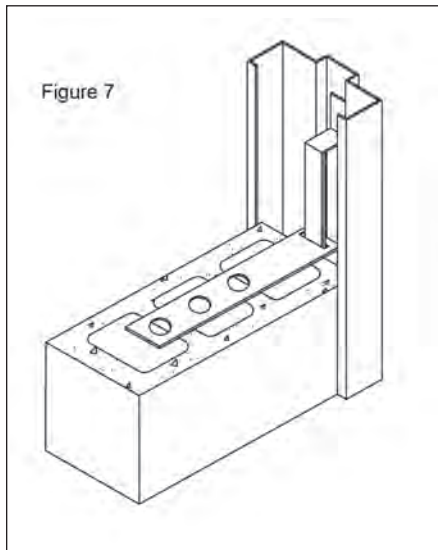

and the height of the frame. These requirements also state the maximum distance between the anchors. They must be spaced no more than 6" from the top and bottom of the frame, with an intermediate spacing not to exceed 26" between anchors.

The location of the anchors are near the hinges and directly opposite on the strike jamb.

New Masonry Walls

In this building condition, the frame is set into the brick or block masonry wall while the wall is being constructed. Once the wall is constructed, the frame is permanently installed and any corrections to a bad installation are very hard to correct.

As the wall is laid up, the anchors are installed or inserted between the course of the bricks or block and are grouted into the opening. (Figure 7) Therefore, it is essential that all angles are checked for being 90 degrees before securing the frame. It's also vital that the frame is checked for squareness, plumbness, alignment and twist in the frame as the wall progresses through being built.

There are four variations of masonry anchors, three of which are shown in Figure 8.

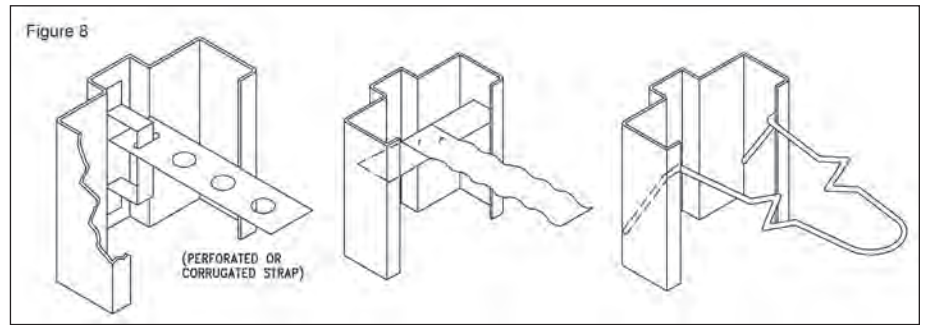

- **T-Strap Anchors.** These are provided loose and are typically specified by architects.
- **Welded-In Strap Anchors.** These straps are typically longer than the T-Strap anchor, as their flexibility comes from bending the anchor up or down to the blocks for alignment.
- **Wire Loop Anchors.** Economically, these are the least expensive and are also provided loose with the frame. They are held into the throat of the frame by pressure. Their main disadvantage is that they are only good up to about an 8 3/4" JW and therefore cannot be used on larger JW frames.
- **Strap and Stirrup Anchors.** These anchors are welded into the frame on a "C" channel on which they can be slid up and down for their adjustability. These are the most expensive of the options.

Steel Stud Walls

Before installation can begin, it is essential that the steel stud manufacturer's recommendations for general construction are followed to ensure that a solid, stable opening is achieved. These instructions include how the horizontal and vertical studs are run in the wall, how they are joined together, and where double studding is required. Extreme precaution must be taken to ensure that any fasteners applied

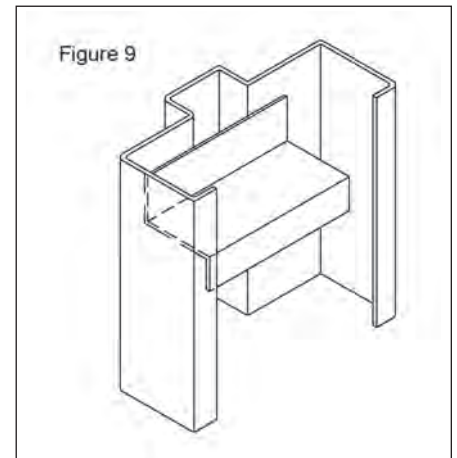

through the face of studs or to any part of the construction do not lead to an increase in the wall thickness.

With steel stud walls, the studs are mechanically fastened to the zee-shaped anchors (Figure 9) that are installed inside the jambs through the throat of the steel stud. There is also a snap-in style of anchor that can be used for most jamb widths.

Due to the irregularities in wall construction width, it is strongly recommended that the frames for stud walls have a throat dimension 1/8" greater than the dimensioned wall thickness. For instance, with a stud thickness of 3 5/8" with two layers of 5/8" sheetrock, the wall thickness is 4 7/8". The typical jamb width that is used is 5 7/8", but the recommendation is to go with a 6" JW frame with a 5" throat.

Wood Stud Walls

Wood stud walls can be constructed either after the frame is

Figure 10

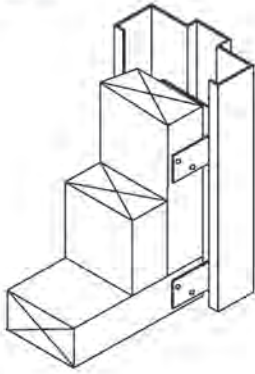

set or prior to setting the frame. As with all wall types, ensure that the frame is square prior to and while attaching the anchors.

The wood stud anchors are tabs that come out of the throat of the frame, wrap around the wood studs and fasten to the studs with nails (Figure 10). The anchor tabs are bent around the stud, leaving the desired clearance between the frame return and the stud for inserting the finished wall material. These tabs have some flexibility for installation. However, if the finished material is thicker than $\frac{3}{4}$ " on each side of the stud, the manufacturer should be notified in advance so that the tabs can be set in to accommodate the material thickness.

Base (or Floor) Anchors

There are two variations on a theme with these anchors: fixed (Figure 11) and adjustable (Figure 12). These anchors are not used in existing masonry or existing concrete walls. Instead, an additional expansion anchor reinforcement is provided. They are also not used in pre-framed stud walls or completed drywall openings. An additional base anchor is included in those applications.

Fixed base, or floor, anchors are welded to the base of each jamb and are typically secured to the floor by

Figure 11

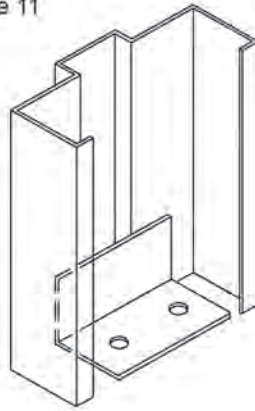

mechanical fasteners. Shimming must be used if the floor is not level.

Adjustable base, or floor, anchors are designed for use where there are significant irregularities from level due to an intended slope in the floor, or where surface toppings such as terrazzo will be used.

Existing Masonry Anchors

Existing masonry frames are set into block, brick or concrete walls, either replacing a frame that has been removed or by cutting a new opening into the wall for passage. It is critical that clearance is allowed between the existing wall opening (rough opening) and the frame. This clearance should be a minimum $\frac{1}{4}$ " at each jamb and $\frac{1}{4}$ " at the head of the frame (Figure 13).

In order to use a standard or stock size door, the frame faces may need to be varied to accommodate the rough opening. For instance, for a rough opening of 40" x 86" to accommodate a 3'-0" x 7'-0" nominal door, the frame faces would need to be 1 $\frac{3}{4}$ " for the jambs and the head. The overall size of the frame would then be 39 $\frac{1}{2}$ " x 85 $\frac{3}{4}$ ". It is critical to remember that the overall size of the frame is smaller than the rough opening. Care in ordering is important, and remember to not order the overall size of the frame equal to the rough opening.

Figure 12

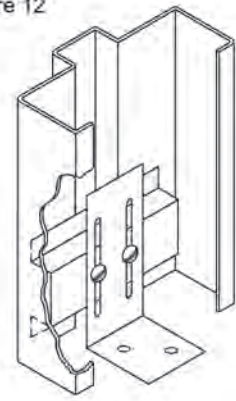
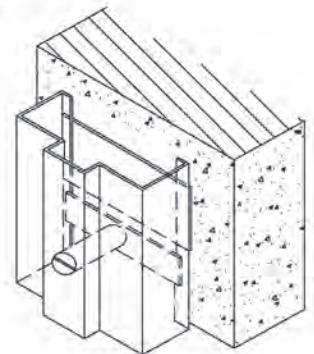

Figure 13



Figure 14



The other option is to keep all faces 2" and adjust the door size as required. In the example shown in the previous paragraph, if you use 2" faces with a 40" x 86" rough opening, the overall size of the frame is still 39 $\frac{1}{2}$ " x 85 $\frac{3}{4}$ ". However, the nominal door opening size is now 2'-11 $\frac{1}{2}$ " X 6'-11 $\frac{3}{4}$ ". A custom-sized door will need to be ordered for this opening.

If there are ADA requirements for the opening, make sure that they are specified and adhered to.

The installation involves inserting mechanical fasteners through the frame soffit into the existing wall (Figure 14). The variations of the anchors used are there to keep the frame soffit from collapsing during this process. It will be necessary to shim behind the anchors and above the bolts to ensure a plumb frame. As with all installations, kept the frame square with the use of spreaders. Tighten the bolts and caulk the gap between the frame and the wall.

Additional Information and TechNotes:

Refer to HMMA 840 for more details on frame installation and storage, as well as information on installed knocked down drywall frames. HMMA also published TechNotes on a variety of subjects. The TechNotes are published to address frequently asked questions and concerns on the following topics:

- *Defining Undercuts:* This document defines a door undercut and what controls the required undercut of the door.
- *Grouting Frames:* Grouting of hollow metal frames is a common practice but can lead to early rusting if the frame is not properly protected or the wrong grout is used. This tech note covers the key grouting issues.
- *Continuously Welded Frames:* The definition and differences between standard welded frames and continuously welded frames

is detailed in this section along with pictures showing exactly where the frames are welded for each type.

- *Glazing Hollow Metal:* This particular document on glazing focuses on the glazing of exterior transom and side-light hollow metal frames.
- *Painting Hollow Metal:* The most common issue that is explored in this note is the gloss rating of the finished paint, and how high gloss paints combined with the ambient light sources can show up the manufacturing welds. It also covers preparation of the material before painting.

Summary:

There are many factors to take into consideration when installing hollow metal frames. In order to ensure a quality installation and a happy customer, be sure that the installing contractor follows all of the steps above as well as any instructions provided by the manufacturer of your doors and frames. If you have any questions, don't hesitate to contact the manufacturer; they'll be more than happy to lend their expertise, as a quality installation reflects on both the installer and the manufacturer. **dh**

About the Author: Rachel S. Smith is President of Karpen Steel Custom Doors & Frames. She has been at Karpen Steel for 23 years. Rachel has contributed a number of articles to *Doors and Hardware* and enjoys teaching others about custom products to fill openings.